

MULTI-MAX PLUS™

Deck Operation INSTRUCTIONS



RAISING THE DECK
Page 3

LOWERING THE DECK
Page 7

May 2024

MULTI-MAX PLUS™ DECK OPERATION INSTRUCTIONS

These instructions show the safe operation of hinging decks on the Greenbrier Multi-Max Plus™—a 20'-2" tall bi-level auto rack optimized for tall van service.

This railcar has hinging end decks that may be loaded in either the raised or lowered position, depending on the load at hand. The current deck setting can be seen from inside the car and also from the outside by way of an indicator at the BL and AR corners. Deck movement is accomplished with the Deck Lift Handle and Latch, as shown in the following figures. Both sides of each hinging deck have a Deck Lift Handle and Latch, and both must be operated. This process can be accomplished with either one person working alone or two people working together.

Deck in RAISED Position

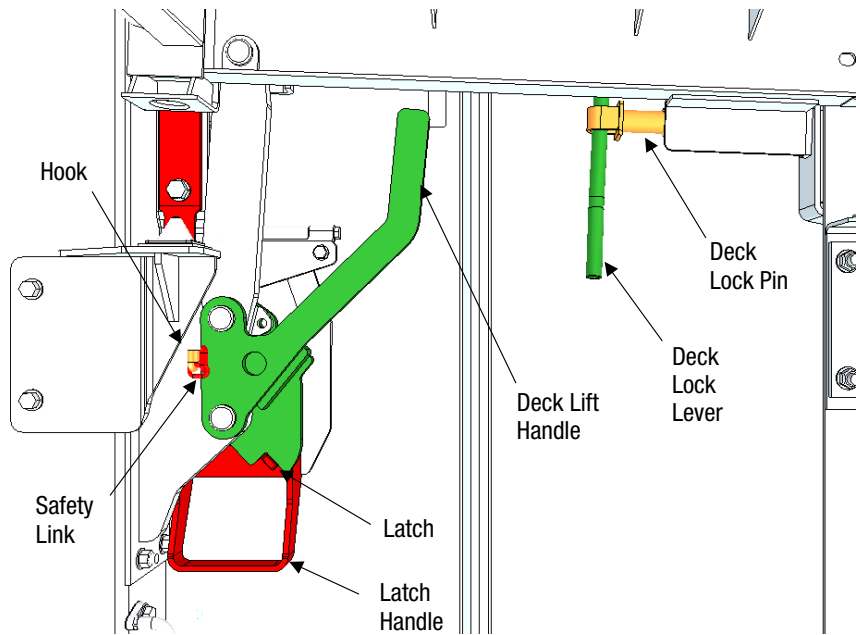

Deck in LOWERED Position

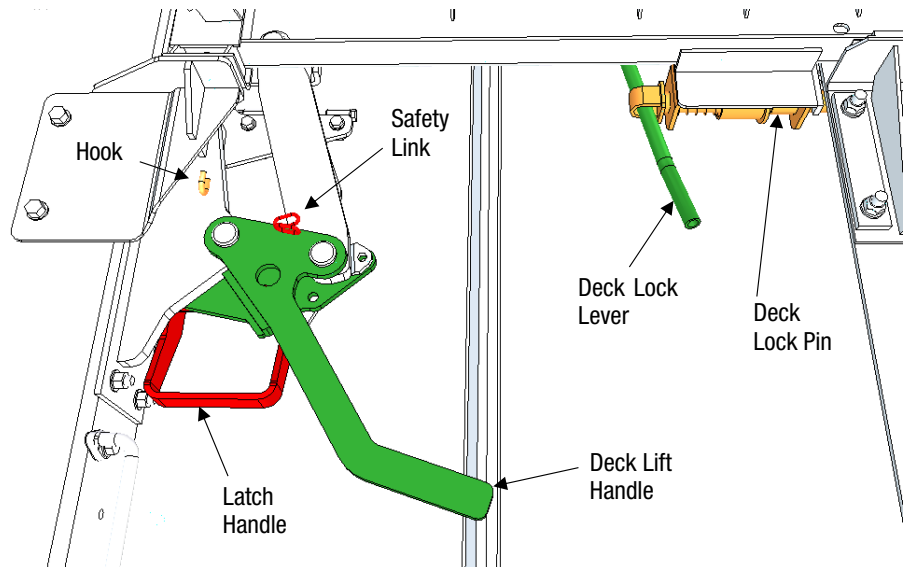

RAISING THE DECK

Note: This operation can begin on either side of the deck.

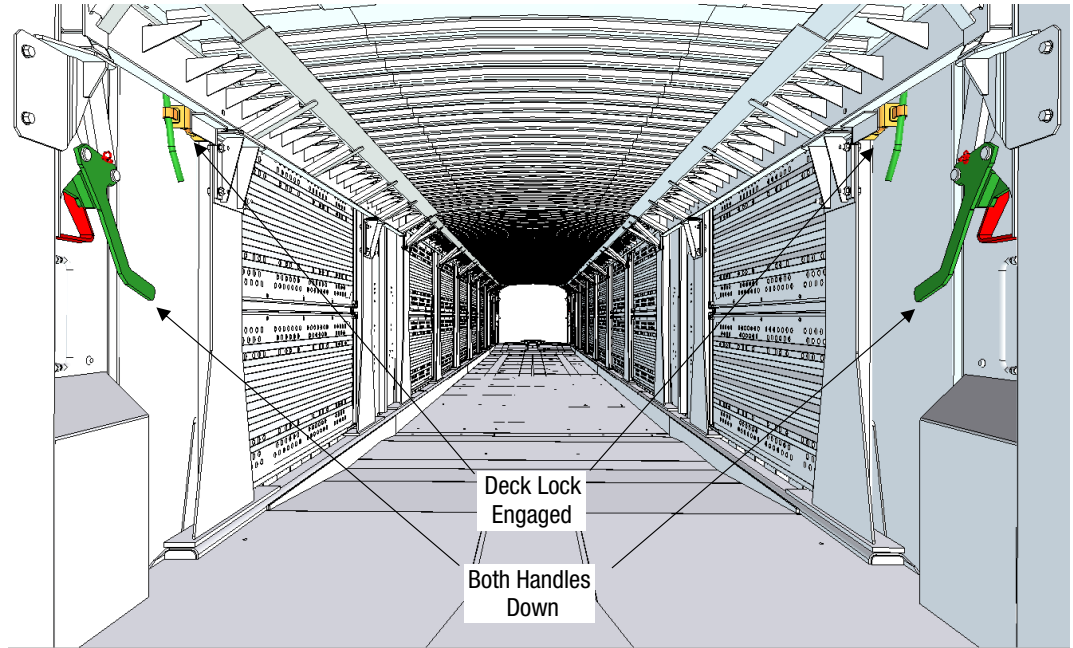

- 1** Pull the Deck Lock Lever to unlock the Deck Lift Handle.

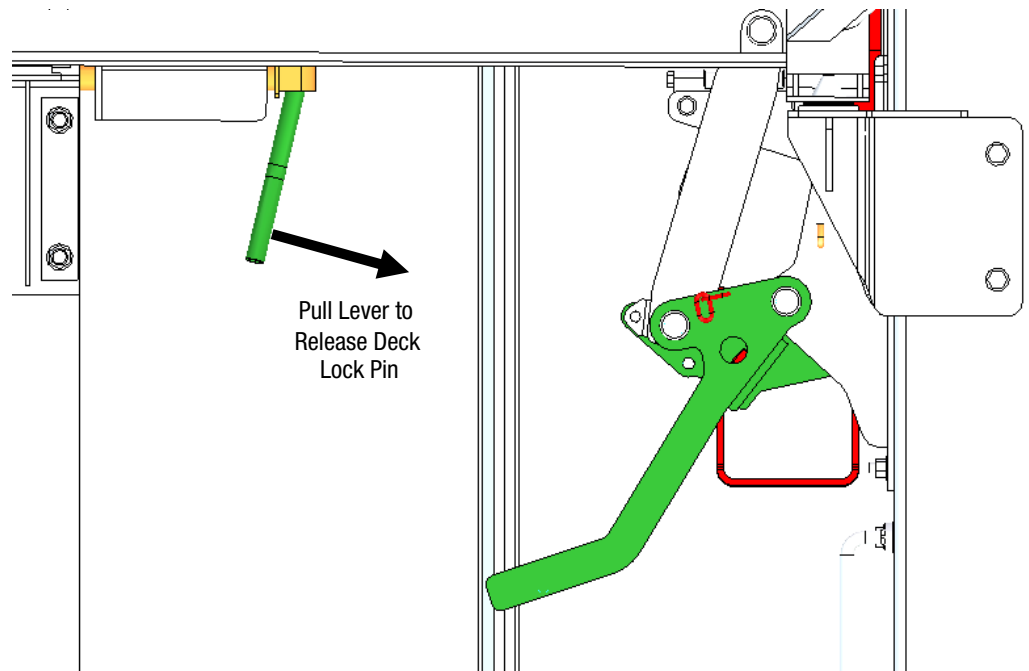

RAISING THE DECK

- 2 While the Lock is still disengaged, push the Deck Lift Handle up to the mid-point. It may naturally release to this position.

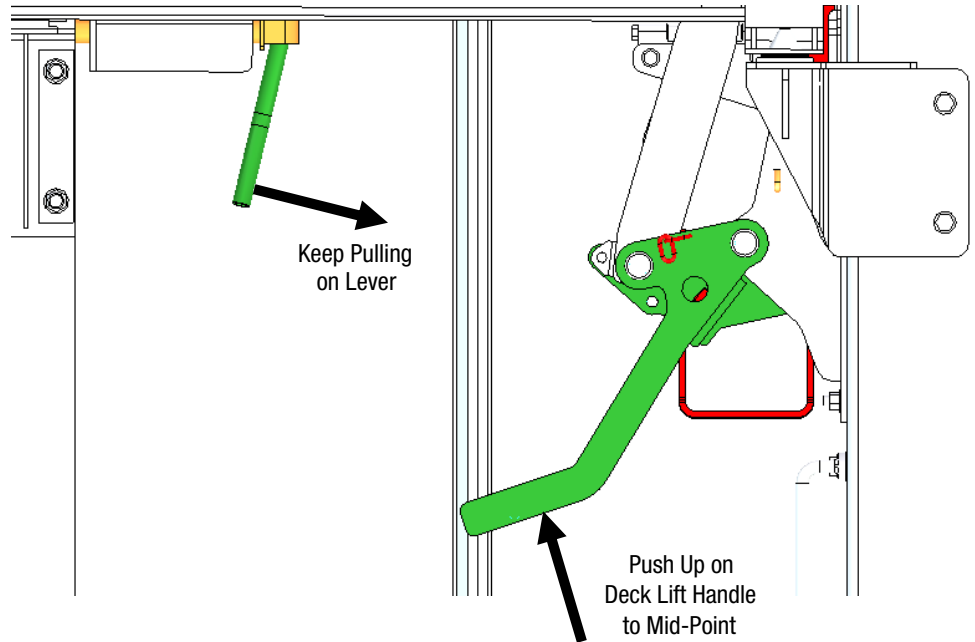

- 3 Repeat steps 1-2 for the other side of the deck so that both sides are unlocked and at the mid-point.

- 4 Starting from either side of the deck, push the Deck Lift Handle up to its stop. The Deck Latch should snap in place on the back side of the Deck Lift Handle.

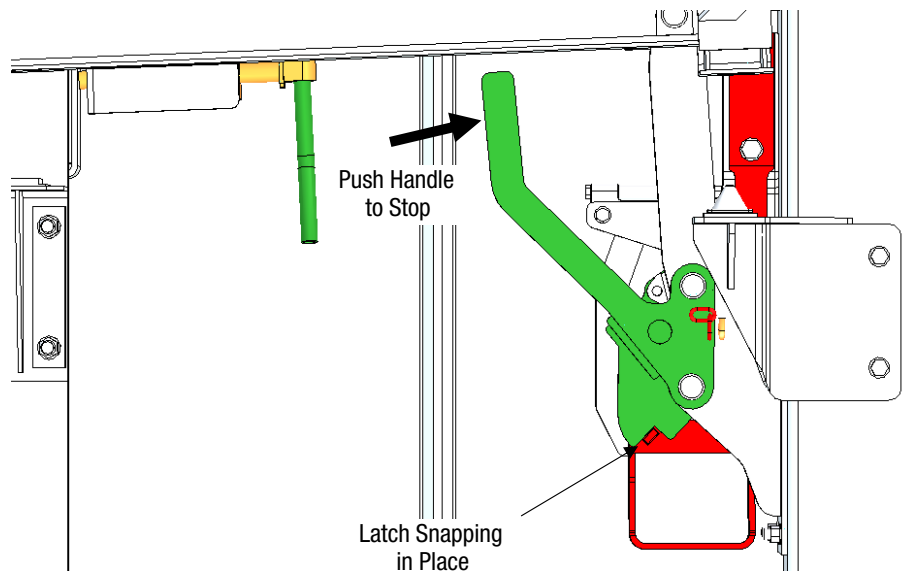

RAISING THE DECK

- 5 Inspect the Latch to insure it is fully engaged. The Latch should be pressed tight against the back of the Deck Lift Handle with very little clearance. If it is not, make sure the Deck Lift Handle is pushed all the way up and pull Latch Handle until it is tight against the Deck Lift Handle.

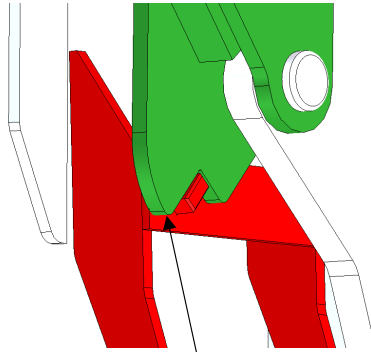

Latch Should Be Tight
Against Deck Lift Handle

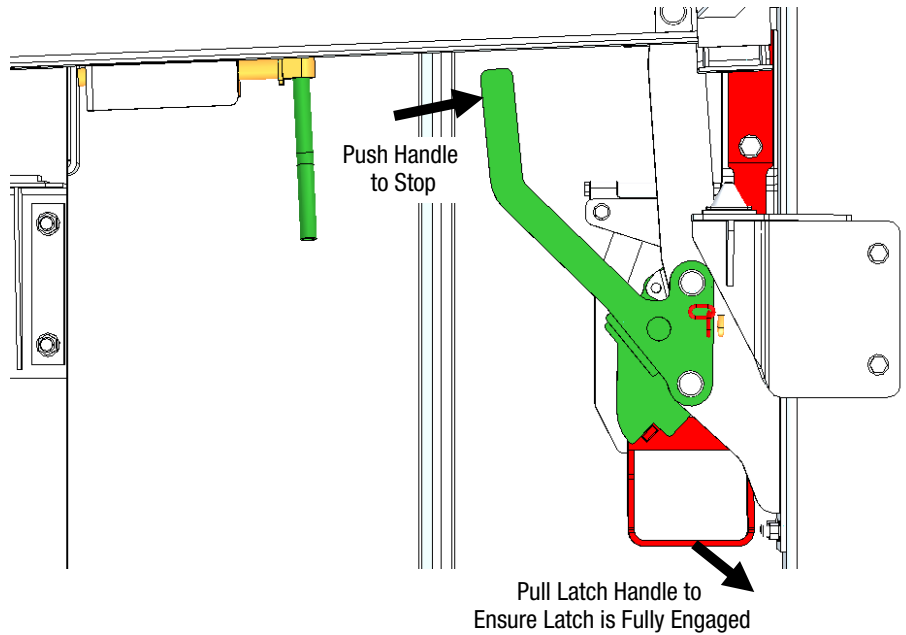

- 6 Apply the Safety Link over the Hook.

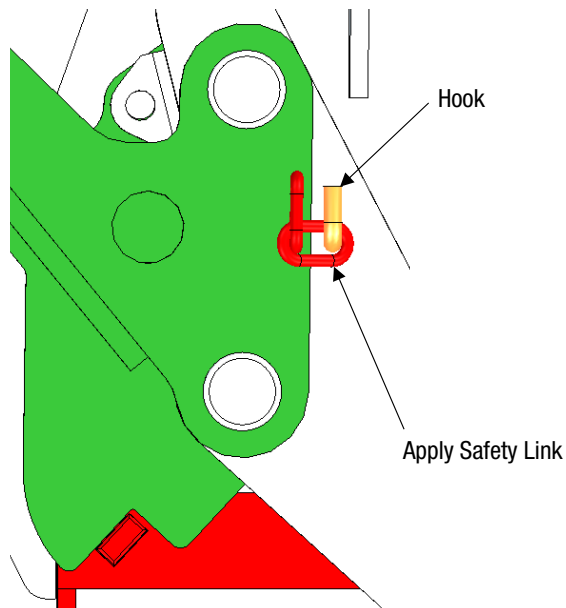

- 7** Repeat steps 4-6 for the other side of the deck. The deck is now in the raised position. The Deck Level Indicator on the outside of the car will show the deck is in the raised position.

IMPORTANT: BOTH SIDES OF THE HINGING DECK MUST BE LATCHED AND HAVE SAFETY LINK APPLIED BEFORE LOADING.

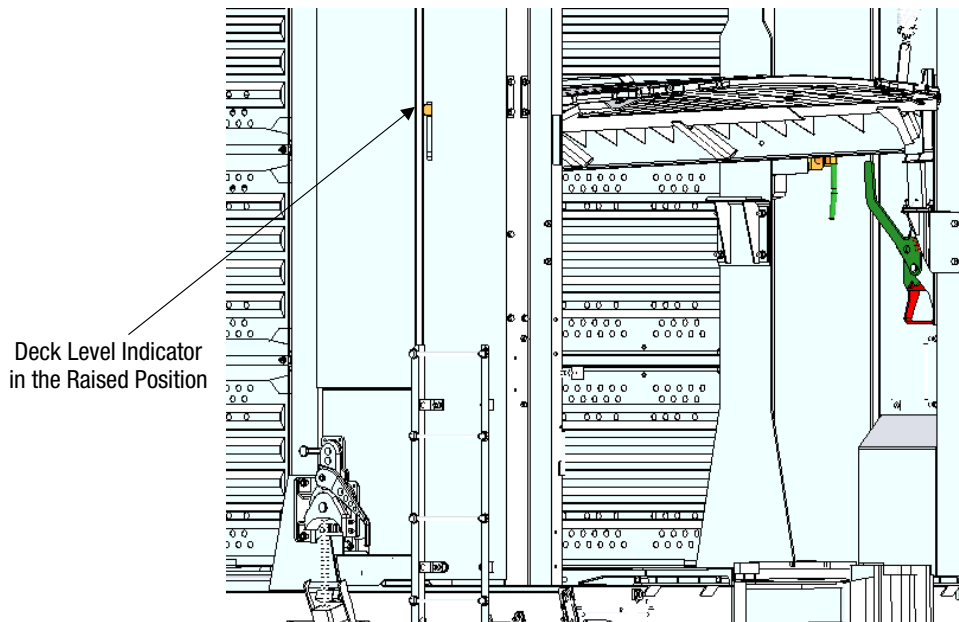
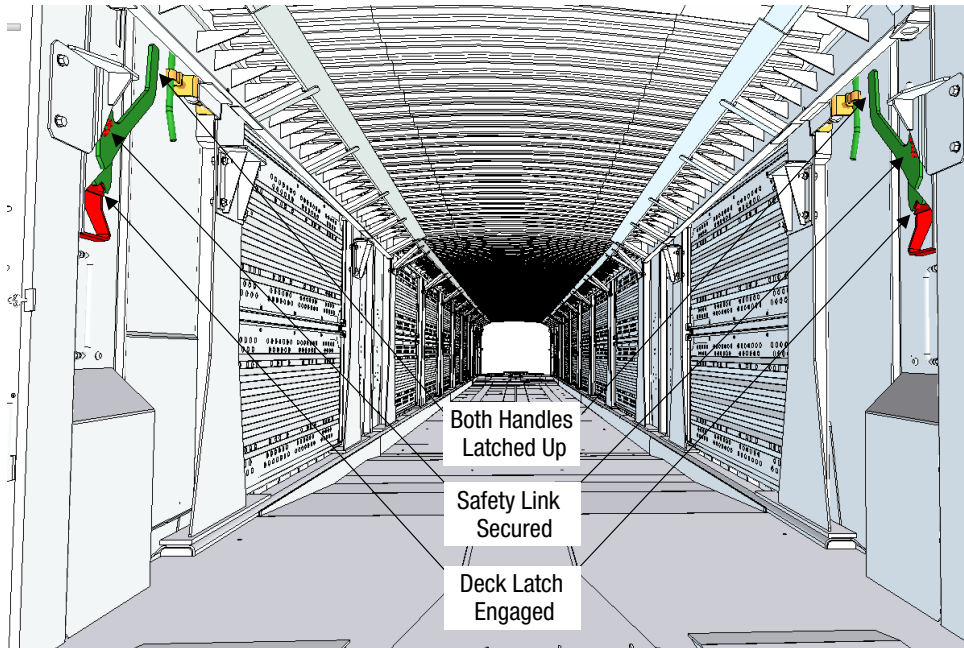

LOWERING THE DECK

Note: This operation can begin on either side of the deck.

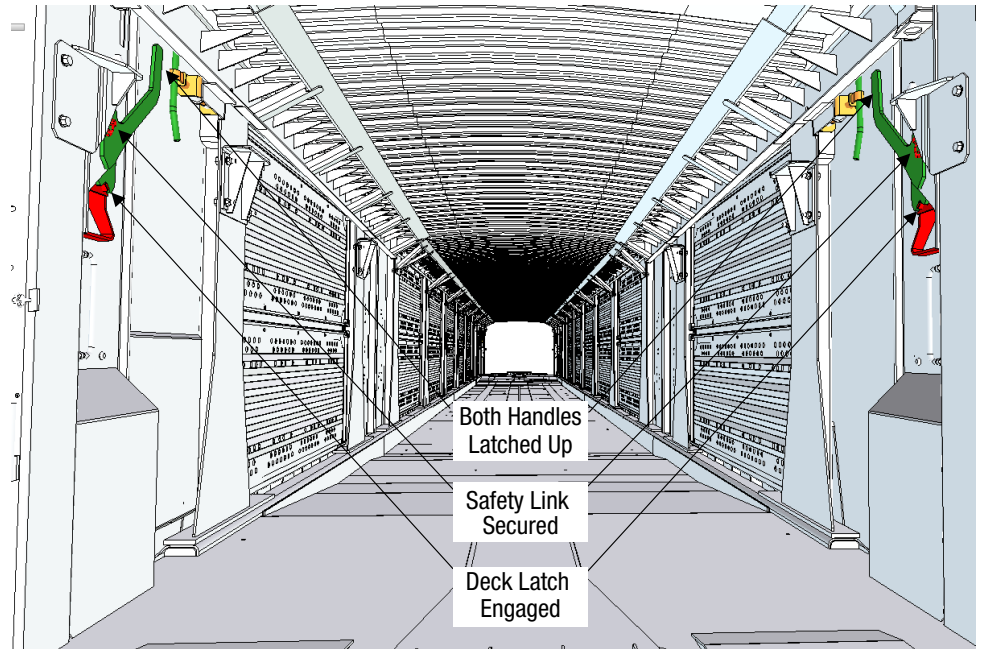

1 Remove the Safety Link from the Hook.

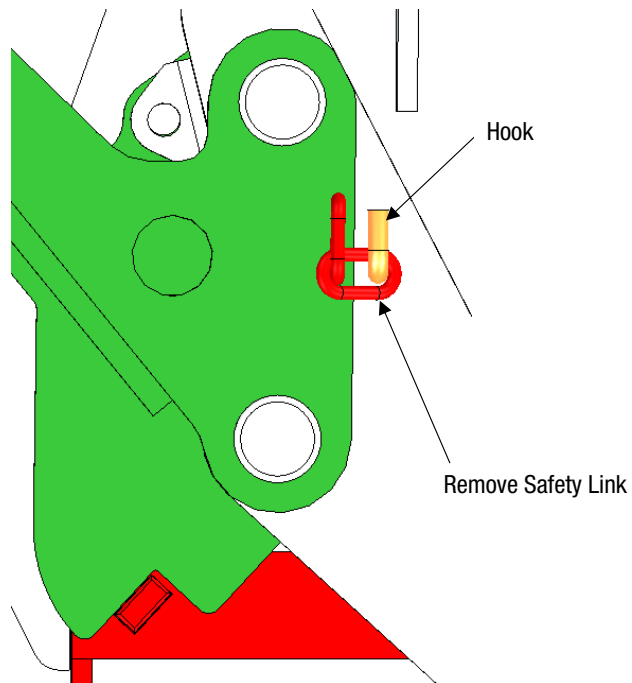

LOWERING THE DECK

- 2** Push the Latch outward to unlatch the Deck Lift Handle.

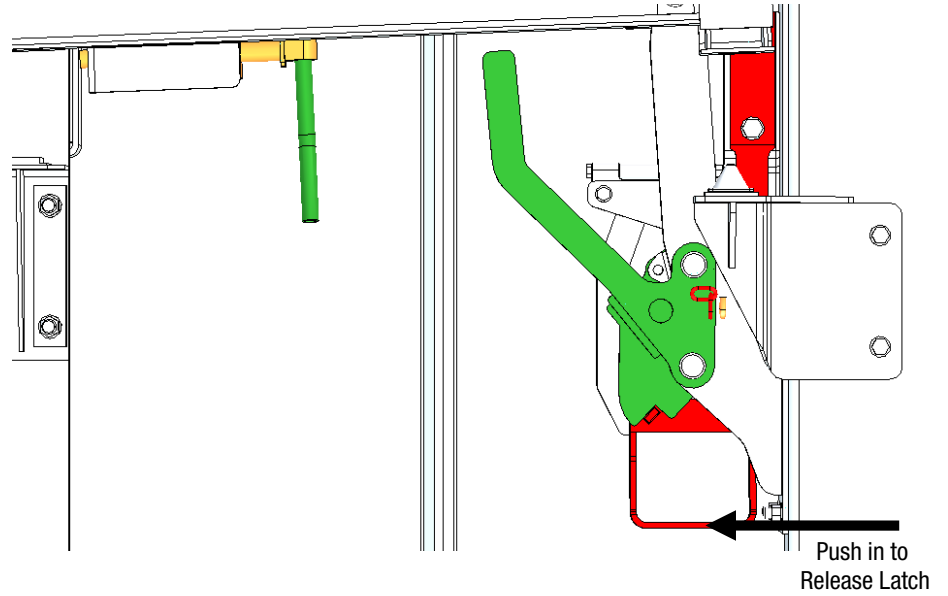

- 3** While the Latch is still disengaged, pull the Deck Lift Handle down to the mid-point. It may naturally release to this position.

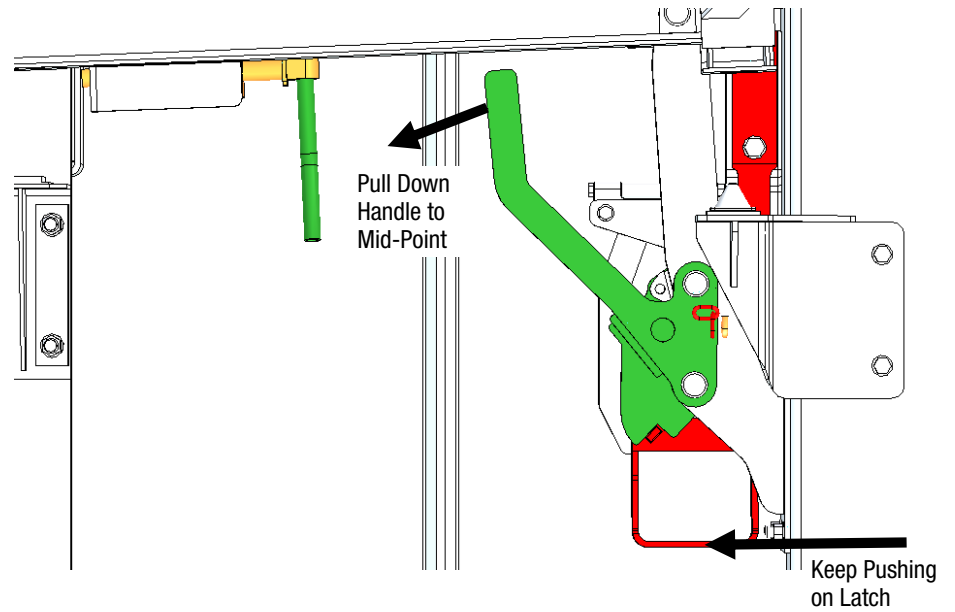

- 4** Repeat steps 1-3 for the other side of the deck so that both sides are unlatched and at the mid-point.

LOWERING THE DECK

- 5** Starting from either side of the deck, pull the Deck Lift Handle down fully. The Deck Lock will automatically lock the deck in place.

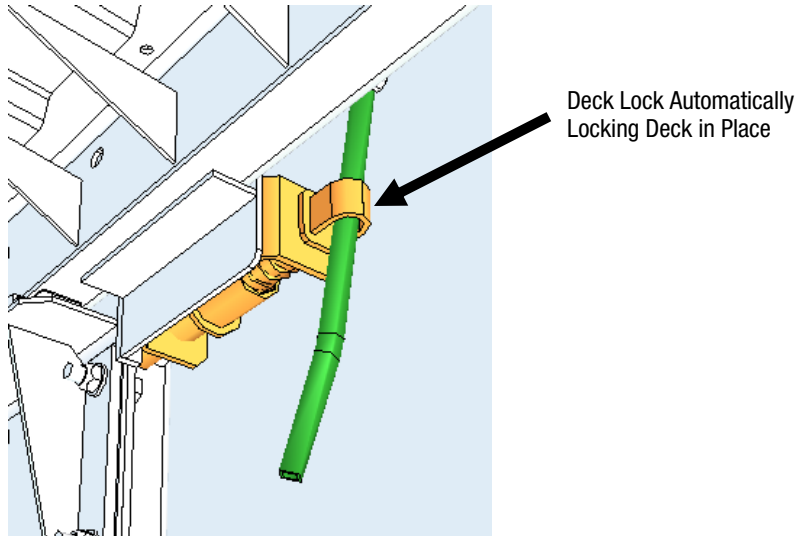

- 6** Inspect the deck to ensure it is completely resting on the Deck Supports. If it is not, make sure the Deck Lift Handle is pulled all the way down.

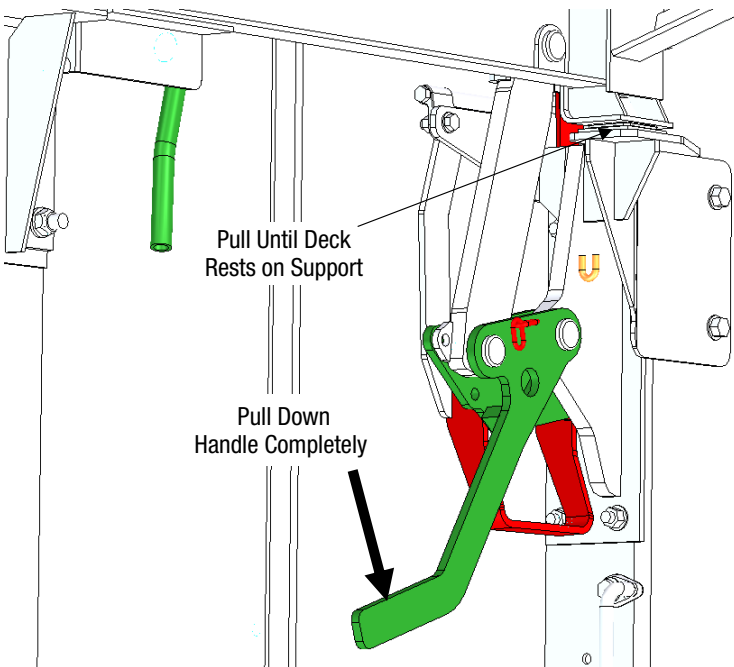
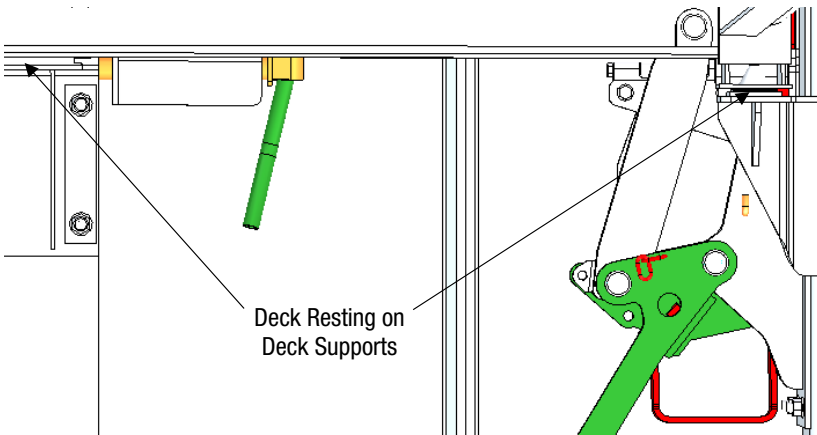

LOWERING THE DECK

- 7** Repeat steps 5-6 for the other side of the deck. The deck is now in the lowered position. The Deck Level Indicator on the outside of the car will show the deck is in the lowered position.

IMPORTANT: BOTH SIDES OF THE HINGING DECK MUST BE LATCHED BEFORE LOADING.

